

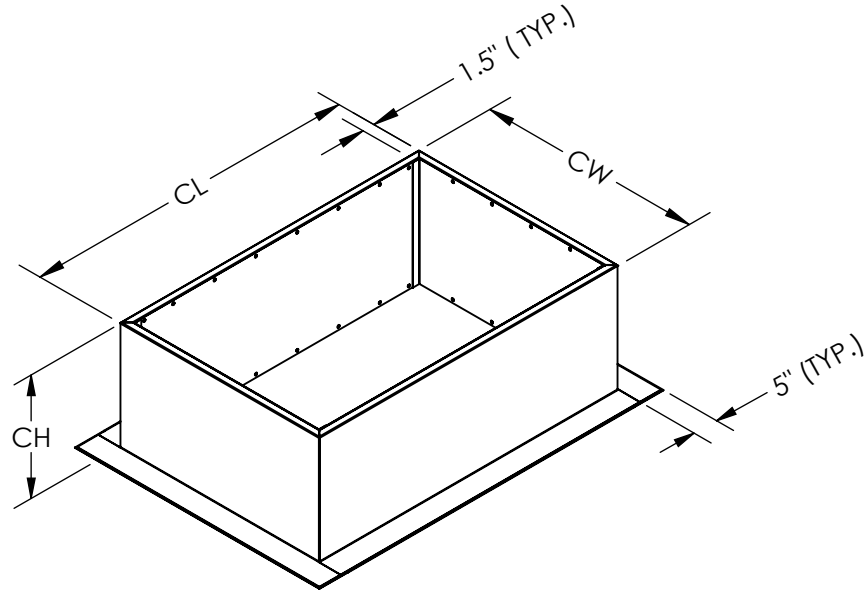

DATE: TAG:
 JOB:
 PROJECT:
 COMPANY:
 SALES PERSON:

vcPLUME-L, CLASS 1, CURB
 HIGH VELOCITY NOZZLE, SIZE 60-270



OPTIONS

Flat Curb Options	Curb Heights (CH)				
	12	14	16	18	24
Non-vented (up to 500F max)	X	X	X	X	X
Non-vented w/ insulation and lined (300F max)	X	X	X	X	X
Vented, no insulation (up to 500F max)				X	X

DIMENSIONAL DATA

Size	ARR 4		ARR 10		WEIGHT(NON-VENTED)(lbs)				
	CL	CW	CL	CW	12"	14"	16"	18"	24"
60-105	38	21	39	21	112	124	135	147	182
122	41	24	44	24	123	134	146	159	196
135	43	27	45	27	136	150	164	178	221
150	45	29	46	29	142	157	171	186	231
165	49	32	51	32	156	172	188	204	254
182	52	34	55	34	164	180	198	215	266
200	56	37	60	37	178	196	215	234	290
222	62	41	63	41	200	220	242	263	326
245	66	44	72	44	210	232	255	277	343
270	69	47	73	47	225	250	274	298	370

ALL DIMENSIONS ARE IN INCHES, WEIGHTS ARE APPROXIMATE .

REVISION:

FORM:

REPLACES:



DATE: TAG:
 JOB:
 PROJECT:
 COMPANY:
 SALES PERSON:

vcPLUME-L, CLASS 1, CURB DUCT DROP
 HIGH VELOCITY NOZZLE, SIZE 60-270

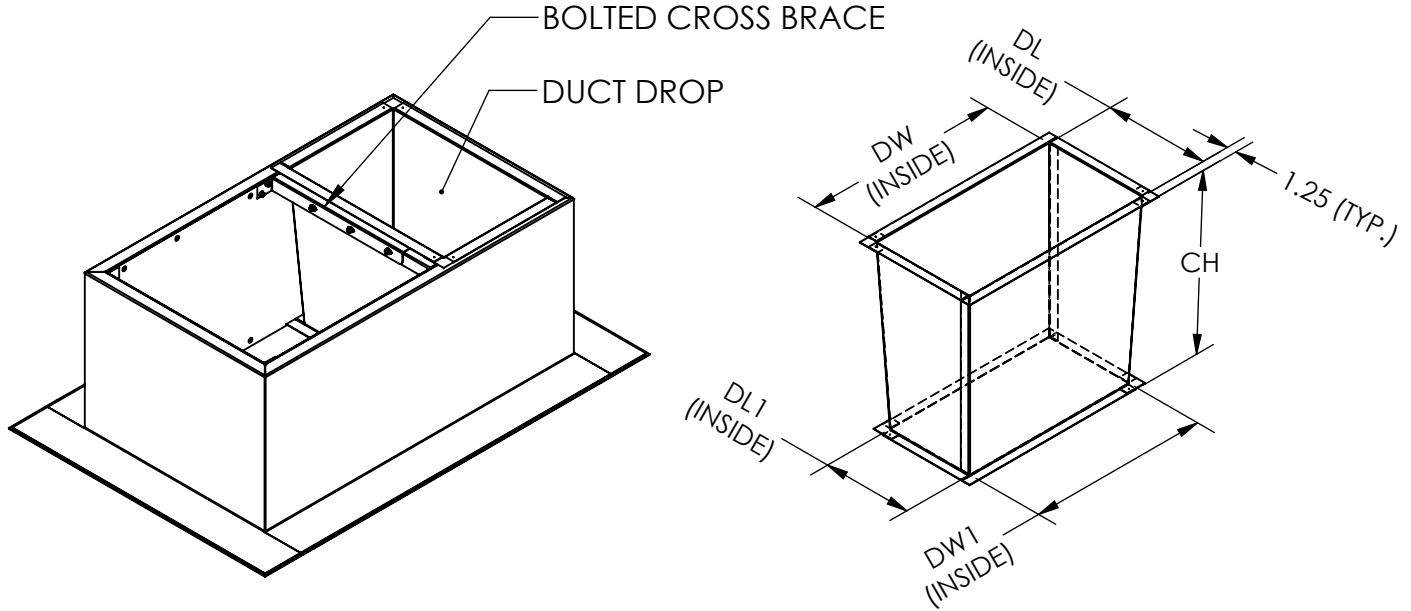

OPTIONS

Curb Heights / Duct Drop (CH)				
12	14	16	18	24
X	X	X	X	X

DIMENSIONAL DATA

Size	ARR 4 & ARR 10		ARR 4 & ARR 10		WEIGHT (lbs)				
	DL	DW	DL1	DW1	12"	14"	16"	18"	24"
60-105	12.19	17.38	9.69	14.88	14	16	18	20	27
122	13.69	20.38	11.19	17.88	16	19	21	23	31
135	13.69	23.38	11.19	20.88	18	20	23	25	33
150	13.69	25.38	11.19	22.88	19	21	24	27	35
165	16.69	28.38	14.19	25.88	21	24	28	30	40
182	18.19	30.38	15.69	27.88	23	26	29	32	43
200	21.19	33.38	18.69	30.88	25	29	33	37	48
222	22.69	37.38	20.19	34.88	28	32	36	40	53
245	24.69	40.38	22.19	37.88	30	34	39	44	57
270	23.19	43.38	20.69	40.88	31	35	40	45	58

ALL DIMENSIONS ARE IN INCHES, WEIGHTS ARE APPROXIMATE .

REVISION:

FORM:

REPLACES: